

ACCESSORI OPZIONALI | OPTIONAL ACCESSORIES

GTA17	Set di 4 gambe con ruote e freno da Ø 80mm	Leg with casters Ø 80 mm
GFA03	Versione opposta	Opposite version
PRF	Piani a rulli in uscita	Out-feed free roller conveyors
GTA-SC	Colore speciale	Special color
1-PH	Versione monofase	Single-phase version

CARATTERISTICHE TECNICHE | TECHNICAL DATA

	GF 056	GF 056 P
Capacità produttiva Productivity	600/800 scatole-boxes/h	600/800 scatole-boxes/h
Consumo aria compressa Air consumption	2,1 nl. per ciclo a 6 bar 2,1 nl. per production cycle at 6 bar	6,0 nl. per ciclo a 6 bar 6,0 nl. per production cycle at 6 bar

Dati indicativi in funzione delle caratteristiche scatole | Indicative data depending on the box configuration

DIMENSIONI | DIMENSIONS

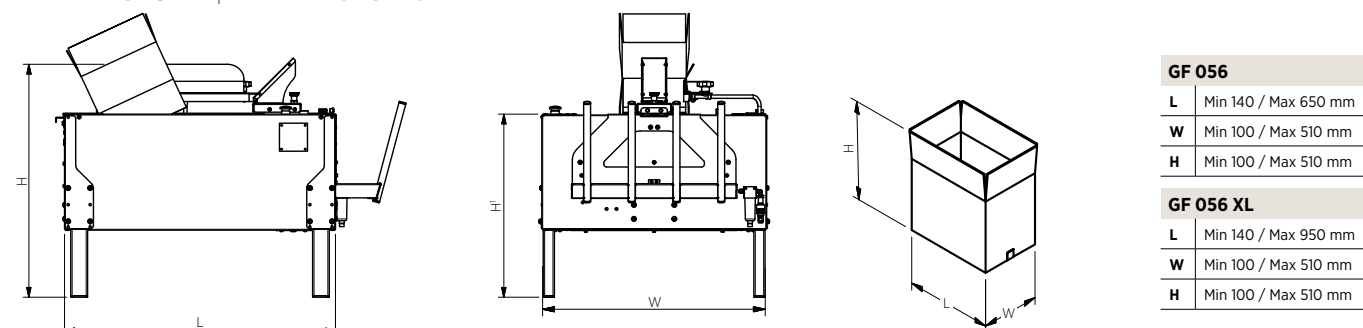

	L	H	H'	W	Kg
GF 056	970 mm	834 mm	655 mm	807 mm	102
GF 056 XL	1270 mm	834 mm	655 mm	807 mm	120

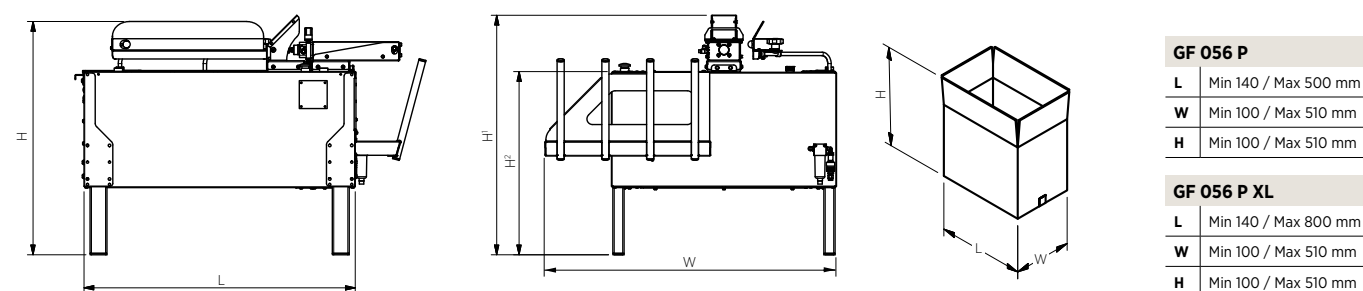

	L	H	H'	H²	W	Kg
GF 056 P	970 mm	834 mm	856 mm	655 mm	1042 mm	115
GF 056 P XL	1270 mm	834 mm	856 mm	655 mm	1042 mm	125

Le caratteristiche tecniche possono essere soggette a variazioni senza preavviso | Specifications subject to change without notice

Altre lingue disponibili | Other languages available: www.elenamarchetti.it |



PACBRO S.r.l.
Via Don Milani, 1 | 20025 Legnano (MI), Italy | Tel. +39 0331 599518 | Fax +39 0331 545291

www.elenamarchetti.it info@elenamarchetti.it [elenamarchettipackagingmachines](https://www.facebook.com/elenamarchettipackagingmachines)



GOLDFLEX 056 - 056P

FORMATORI SEMI-AUTOMATICI
REGOLAZIONE MANUALE SUI DIVERSI FORMATI SCATOLA
SEMI-AUTOMATIC CASE ERECTORS
MANUALLY ADJUSTABLE ON DIFFERENT BOX SIZES



PACKAGING MACHINES

CE
Made in Italy



▲
GOLDFLEX 056 P



▲
REGOLAZIONE LARGHEZZA SCATOLA
ADJUSTMENT BOX WIDTH



▲
GOLDFLEX 056



▲
GOLD SYSTEM 056

FOCUS

Formatore semiautomatico di scatole di tipo americano con la funzione di ripiegare le quattro falde inferiori e sostenerle durante le operazioni di riempimento da parte di un operatore.

- **MACCHINE ROBUSTE ED AFFIDABILI**
- **REGOLAZIONI SEMPLICI E VELOCI**
- **MINIMA MANUTENZIONE**

Semi-automatic case erector to form uniform sized American-type boxes to fold the four bottom flaps and to support the carton during the filling made by an operator.

- **HEAVY DUTY & RELIABLE MACHINES**
- **QUICK AND EASY CHANGEOVERS**
- **MINIMAL SERVICING**



PUNTI CHIAVE / KEY FEATURES

- Viene regolato manualmente sulle dimensioni scatola
Manually adjustable on different box sizes by means of lateral guides
- Dotato di magazzino laterale per appoggio scatole da formare
Equipped with a side magazine for holding the blanks to form
- Dotato di chiudi-falde laterale, che azionato tramite comando pneumatico mantiene chiuso il fondo delle scatole agevolandone le operazioni di riempimento
Equipped with flap closer which keep the bottom closed, making filling easier
- Rulli incorporati sul chiudi-falde facilitano lo scorrimento della scatola verso la stazione di nastratura/sigillatura
Thanks to a free roller conveyor incorporated in the flap folder, the boxes run easily into the sealing station
- Nella versione con spintore GF056-P le scatole vengono spinte pneumaticamente alla stazione di nastratura/sigillatura, velocizzando l'operazione
In the GF056-P model the boxes are driven in the sealing station by means of a pneumatic pusher activated by the operator, optimizing the efficiency
- Abbinato ad una nastratrice (con o senza chiudi-tre-falde) con rulliera/estensibile in uscita, costituisce una linea di imballo semiautomatica compatta e produttiva
Combined with a sealing/glueing machine & out-feed conveyor it becomes a compact, semi-automatic, productive packaging line
- Tutte le macchine sono prodotte in Italia e rispettano le normative CE
All the machines are entirely manufactured in Italy according to EEC Standards